



TELEVISION

Lighting



CATALOG TV-5

KLIEGL BROS

UNIVERSAL ELECTRIC STAGE LIGHTING CO., INC.
321 WEST 50th STREET NEW YORK 19, N. Y.



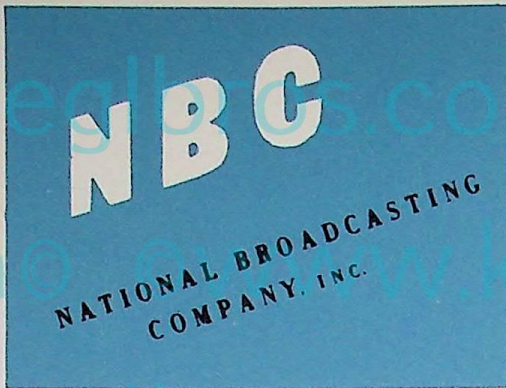

Dear Mr. Kliegl:

The last year has been a critical one for Television Operations. The tremendous growth of this new industry has given us many problems to solve.

Your Organization has been most cooperative in our lighting problems. The development of special distribution systems, dimmer boards and lighting fixtures, with rapid delivery, was a real contribution to our operations.

Please extend our thanks to the members of your organization.

January 11, 1950

Sincerely,

A handwritten signature in black ink that reads "Robert E. Shelby".

Robert E. Shelby
Director of Television
Engineering Operations

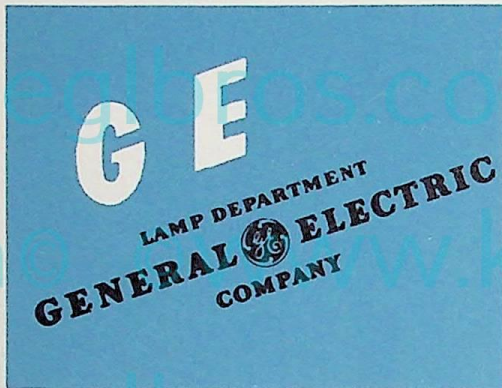

Dear Mr. Kliegl:

I am enclosing two copies of the candlepower distribution curves #165-FM-19347 of the 6-lamp 64T6 slimline television studio lighting unit #TV664G4. The maximum beam candlepower is slightly greater than any similar unit I have seen and the efficiency of 82% is very good. I do note that 11% of the lumens are radiated in the 30° zone between 60° and 90°; the units of this general design show about 4 or 5% radiation in this region.

Since these data have finally arrived, I have hopes that the Photometric Section will continue their activity in television units and will run your other unit in the near future.

January 19, 1949

Very truly yours,

A handwritten signature in black ink that reads "Richard Blount".

RICHARD BLOUNT



Dear Mr. Kliegl:

In the building of television studios in five cities during the past year and a half, we have received the cooperation of several first line organizations engaged in such work.

I wish to acknowledge and express my appreciation for the cooperation and service rendered by your company in connection with the lighting of our television studios. The lighting equipment furnished by you has performed within our design specifications. The patch-plug wiring and control equipment jointly engineered by Kliegl and ABC has contributed substantially toward providing flexible television lighting at low installation and operating cost.

January 10, 1950

Very truly yours,

A handwritten signature in black ink that reads "Frank Marx".

Frank Marx
Vice President

Foreword

Great Strides have been made in the past two years in the design and use of television lighting equipment, in the planning of wiring devices, and in the camera tube itself.

The latest tube, No. 5820, due to its sensitivity, requires a great deal less light. But, as did the former types of tubes, (Nos. 5769 and 5655) the No. 5820 calls for a multiplicity of lighting units to assure the nicety of effects for which the industry is striving.

Last year, 2000- and 5000-watt fresnel spots were often needed for highlighting. Today, the 1000-1500-watt No. 44N8 unit, or the 500-watt No. 44N6 are of sufficient intensity with the No. 5820 tube.

It is to be noted however that the biggest step forward is in the KLIEGL wiring and controlling of lights, as exemplified in the new "KLIEGL Patch Plug Wiring and Control System," which we proudly present on pages 12 to 17 of this catalog. This new system has already been adopted and installed by several of the major chains, including WOR-TV, WRBG, WJZ-TV and NBC-TV. It confers the ability to locate lights wherever needed, with a minimum of labor, and with individual control and dimming when desired.

Kliegl lights themselves have been refined, and new equipment designed to meet the ever-increasing demands of producers and technicians. The advancements in each type of equipment are listed under the respective headings.

All precautions, as learned in our 54 years in the design and manufacture of lighting equipment and wiring devices, are incorporated in our TV line. This assures you complete electrical protection of studio personnel, actors and actresses. We have taken no "short cuts". The "Underwriters' Label" is your assurance.

We are staffed to furnish you expert engineering service to help you work out your studio lighting and wiring problems. Please note that our standard lighting equipment can be modified to meet special requirements. We can manufacture special units to your specifications.

Your inquiries are solicited.

KLIEGL BROS. UNIVERSAL ELECTRIC STAGE LIGHTING CO. INC.
321 West 50th Street • New York 19, N. Y.

CONTENTS

	PAGE		PAGE
Accessories		Floodlights	
Barn Doors	9, 26	Scoops	8, 9, 10
Colorframes	9, 26	Baby Scoops	9
Diffuser Mediums	26	Long Range Scoops	10
Lamp Bulbs	26	Kliegsuns	11
Background Projection		Floor Floods	20
Projectors	23	Striplights	20
Scenic Effects	23	General Lighting	
Slide Changers	23	Miscellaneous	27
Base Lights		Hanging Devices	
Fluorescent	6	Portable Scenery Supports	25
Slimline	4, 5	Klieglights	
Control Systems		Floor and Suspension Type	21
Permanent	12, 13	Wiring Devices	
Portable	14, 15	Cable	19
Fresnel Spots		Connectors	19
Units and Stands	7	Plugging Boxes	18
		Wall Boxes	18, 19
		Patch Boxes	19
		Stand Switches	7

NEW SLIMLINE BASE LIGHTS

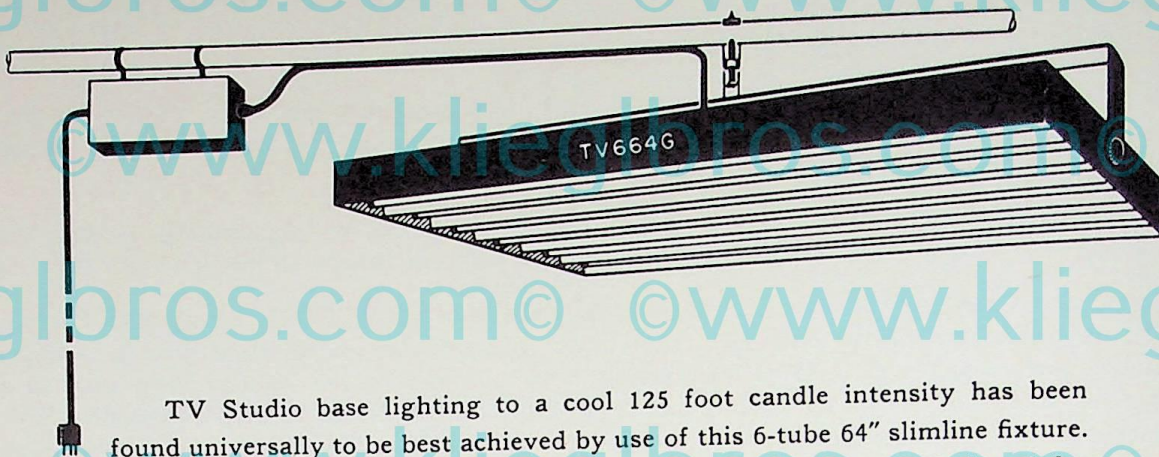

TV Studio base lighting to a cool 125 foot candle intensity has been found universally to be best achieved by use of this 6-tube 64" slimline fixture. Its polished Alzak-finished aluminum reflector has been newly designed for the greater projection heights of 12 to 17 feet. Combinations of 4500° and soft white lamps make this lighting ideal for the new orthicon tubes.

Separate ballast boxes for the 6-tube units are available with either a 5-conductor (includes ground) rubber feed cable with male connector for 1/3, 2/3 or full intensity operation or with a 3-conductor (includes ground) rubber feed cable and male connector for full intensity operation only. Four (4) tube units are wired with a 3-conductor (includes ground) rubber feed cable and male connector.

LIGHTING FIXTURES

Slimline No. TV664G — For six 64" slimline lamps, all aluminum construction with individual 20-gauge polished Alzak-finished aluminum reflectors, wired with 10 ft. 11-conductor rubber cable (includes ground leg). Instant starting. Size: 64" x 26³/₄" x 3¹/₂" deep. Weight, 39 lbs., with new yoke and malleable iron C clamp for 1¹/₂ to 2" pipe. Price:

Slimline No. TV464G — For four 64" slimline lamps, as above, wired with 10 ft. 8-conductor rubber cable (includes ground leg). Instant starting. Size: 64" x 16³/₄" x 3¹/₂" deep. Weight, 33¹/₂ lbs. Price:

TRANSFORMER BOXES

TV664BG5 — Surface type box with 3-tulamp 300 MA slimline ballasts, terminal connecting block and 25 ft. 5-conductor (includes ground) rubber cable with 5-pole male #5950B plug for 1/3, 2/3 and full intensity operation. Complete with pipe brackets for hanging. Weight, 60 lbs. Price:

Additional 5-conductor cable. Price: per ft.

TV664BG — Identical ballast box but wired with 10 ft. 3-conductor (includes ground) rubber cable, 3-pole #955G male connector for full intensity operation only. Weight, 58 lbs. Price:

TV464BG — Surface type box with 2-tulamp 300 MA slimline ballasts and 10 ft. 3-conductor (includes ground) rubber cable, 3-pole male #955G connector for full intensity operation only. Complete with pipe brackets for hanging. Weight, 44 lbs. Price:

Additional 3-conductor rubber cable. Price: per ft.

Ballast boxes with ballasts for remote locations available. Prices on application.
Slimline units with special long range reflectors for 20 ft. grids are available. Prices on application.
Roller caster stand models for floor and footlight use are available. See page 20.

NEW "ALL-IN-ONE" SLIMLINE BASE LIGHTS

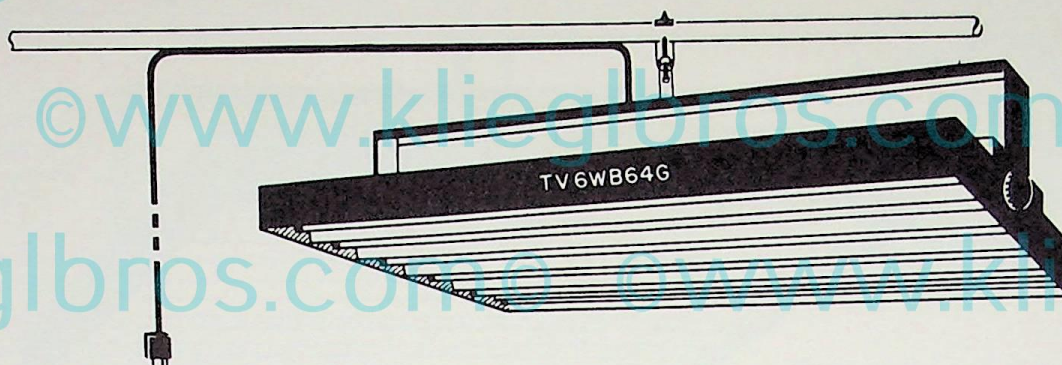

Using the same basic reflector design and producing the identical lighting as those described on page 4, these units have the ballasts built into the housing, making a completely assembled and wired, one-piece instrument. Useful where a mobile grid is used for raising and lowering them and where their location is not to be moved frequently. Yoke and C clamp permit full rotation and angular adjustment to meet studio requirements. Six tube units are wired with either a 5-conductor (includes ground) feed cable and male connector for 1/3, 2/3 and full intensity operation or with a 3-conductor (includes ground) feed cable and male connector for full intensity operation only. Four tube units are wired with a 3-conductor (includes ground) rubber feed cable and male connector.

Slimline No. TV6WB64G5 — For 6-64" slimline lamps, all aluminum construction, with individual 20-gauge polished Alzak finished aluminum reflectors and with 3 built-in tulamp 300 MA ballasts, completely wired with 25 ft. 5-conductor (includes ground) feed cable and male #5950B connector for 1/3, 2/3 or full intensity operation— instant starting. Size: 64" x 26 $\frac{3}{4}$ " x 4 $\frac{3}{4}$ " deep. Weight 85 lbs., with yoke and malleable iron C clamp for 1 $\frac{1}{2}$ to 2" pipe. Price:

Additional 5-conductor rubber cable.

Price: per ft.

Slimline No. TV6WB64G — Identical 6 light unit but with 10 ft. 3-conductor (includes ground) rubber cable and male #955G connector for full intensity operation only. Price:

Slimline No. TV4WB64G — For 4-64" slimline lamps as above and wired with 10 ft. 3-conductor (includes ground) rubber cable and male connector. Size: 64" x 16 $\frac{1}{4}$ " x 4 $\frac{3}{4}$ ". Weight, 63 lbs.

Price:

Additional 3-conductor rubber cable.

Price: per ft.

IMPORTANT . . .

Slimline units with special long range reflectors for 20 ft. grids are available. Prices on application. Correctly designed 42" and 8' slimline units as well as modifications of those listed are available. Prices on application. Roller caster stand models for floor and foolight use are available. See page 20.

NEW FLOURESCENT BASE LIGHTS

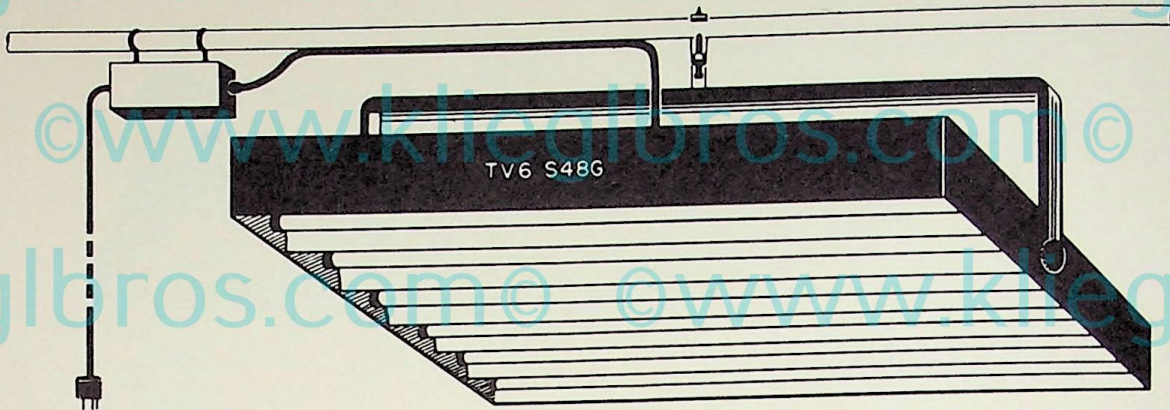

Now available in 4 light and 6 light 40 watt units, these fluorescent fixtures meet the needs of the smaller low ceiling height studios. Of same general design and construction as the slimline fixtures with correctly designed Alzak reflector for the larger diameter 40 watt lamp, they are available with separate ballast boxes or with inbuilt ballasts, "All in One Construction". Furnished with instant start ballasts.

LIGHTING UNITS

Fluorescent No. TV6S48G — For 6 - 40 watt fluorescent lamps, all aluminum construction with individual 20 gauge polished Alzak finished aluminum reflector wired with 10 ft. 11-conductor rubber cable (includes ground leg). Instant starting, size 48" x 44" x 4". Weight 64 lbs., with yoke and malleable iron C clamp for 1½ to 2" pipe.

Price:

Fluorescent No. TV4S48G — For 4 - 40 watt fluorescent lamps, as above, wired with 10 ft. 8-conductor rubber cable (includes ground leg). Size: 48" x 29" x 4". Weight 50 lbs.....Price:

BALLAST BOXES

No. TV6S48BG — Surface type box with 3 - tulamp instant start 40 watt ballasts and with 10 ft. 3-conductor (includes ground) rubber cable, male #955G connector and pipe bracket for hanging. Weight, 52 lbs..... Price:

No. TV4S48BG — Surface type box for the 4 light fixture with 2 - tulamp instant start 40 watt ballasts and with 10 ft. 3-conductor (includes ground) rubber cable, male #955G connector and pipe bracket for hanging. Weight, 42 lbs...Price:

Additional 3-conductor rubber cable.

Price: per ft.

"ALL IN ONE" CONSTRUCTION

No. TV6WBS48G — For 6 - 40 watt fluorescent lamps, constructed similar to above but with 3 built-in instant start 40 watt tulamp ballasts; completely wired with 10 ft. 3-conductor (includes ground) rubber cable, male #955G connector, yoke and malleable iron C clamp for 1½ to 2" pipe. Size: 48" x 44" x 5". Weight, 101 lbs. Instant starting.Price:

No. TV4WBS48G — For 4 - 40 watt fluorescent lamps, as above, and wired with 10 ft. 3-conductor (includes ground) rubber cable, male #955G connector and 2 built-in tulamp instant start ballasts. Size: 48" x 29" x 5". Weight, 78 lbs.

Price:

Correctly designed 3 light fluorescent units and units for all sizes of fluorescent lamps as well as modifications of those listed are available. Prices on application.

Ballast boxes with ballasts for remote locations are available. Prices on application.

New FRESNEL LENS SPOTLIGHTS



No. 44N12TVG

Redesigned and modified, these new Fresnel spots have front and back spindle adjustment control — more sturdily constructed with no increase in weight. The heat resisting lenses with the special ceramic painted black risers provide perfect control of the light beam without any spill light or side glare. They are very efficient, extremely portable and adjustable from wide spread to minimum spot position easily and quickly. Good for any studio distance.

Each is complete with Alzak-finished aluminum reflector, C clamp, yoke, grip handle, heat resisting Fresnel lens with painted risers, front and rear spindle feed adjustment handle, 3 ft. asbestos leads, and male connector.

The switches have been eliminated as the new wirings system provides switchboard control. Switches may be had at slight additional cost.

HOODS

Cat. No.	Lens Size	Lamp Size	Male Conn. No.	Ground Leg	Price
44N3TVG	3"	100/150 watt Bayonet Base†	955G	Yes	
44N3TV	3"	100/150 watt Bayonet Base†	955	No	
44N6TVG	6"	500/750 watt, T-20, Md. Pf. Base	955G	Yes	
44N6TV	6"	500/750 watt, T-20, Md. Pf. Base	955	No	
‡44N8TVG	8"	1000/1500/2000 watt, G-40, Mog. Pf. Base	955G	Yes	
‡44N8TV	8"	1000/1500/2000 watt, G-40, Mog. Pf. Base	955	No	
‡44N12TVG	12"	2000 watt, G-48, Mog. Bip. Base	955G	Yes	
‡44N12TV	12"	2000 watt, G-48, Mog. Bip. Base	955	No	
‡44N16TVG	16"	5000 watt, GT64, Mog. Bip. Base*	3957	Yes	
‡44N16TV	16"	5000 watt, GT64, Mog. Bip. Base*	957	No	

* Adapter, for 44N16 unit for use with 2000 watt G-48 mogul base lamp —
 † Furnished with table base ‡ Cast aluminum front and back construction

STANDS

1420CR	19" Roller caster stand for #44N6 and #44N8 units, with yoke stud
1421CR	25" Roller caster stand for #44N8 and #44N12 units, with yoke stud
1422CR	30" Roller caster stand for #44N16 units, with yoke stud

SWITCHES FOR STANDS

30 amp., 2-pole knife switch with pigtail male and 2 ft. pigtail, 3 pole (1 ground), #955G female connector.	Price:
30 amp., 2-pole knife switch with pigtail male and 2 ft. pigtail, 3-pole (no ground), #955 connectors.	Price:
60 amp., 2-pole knife switch with pigtail male and 2 ft. pigtail, 3 pole (1 ground), #3957 female connector.	Price:
60 amp., 2 pole knife switch with pigtail male and 2 ft. pigtail, 2-pole (no ground), #957 connectors.	Price:

RUBBER CABLE

For Use with	Description	Connector	Ground Leg	Price
44N3TVG	25' #14 — 3 conductor	955G female and male	Yes	
44N6TVG	25' #14 — 3 conductor	955G female and 315 plug	Yes	
44N8TVG				
44N3TV	25' #14 — 2 conductor	955 female and male	No	
44N6TV	25' #14 — 2 conductor	955 female and 301½ plug	No	
44N8TV				
44N12TVG	25' #12 — 3 conductor	955G female and male	Yes	
44N12TVG	25' #12 — 3 conductor	955G female and 315 plug	Yes	
44N12TV	25' #12 — 2 conductor	955 female and male	No	
44N12TV	25' #12 — 2 conductor	955 female and 301½	No	
44N16TVG	25' # 6 — 3 conductor	3957 female and male	Yes	
44N16TVG	25' # 6 — 3 conductor	3957 female and 2301 male	Yes	
44N16TV	25' # 6 — 2 conductor	957 female and male	No	
44N16TV	25' # 6 — 2 conductor	957 female and 301 male	No	

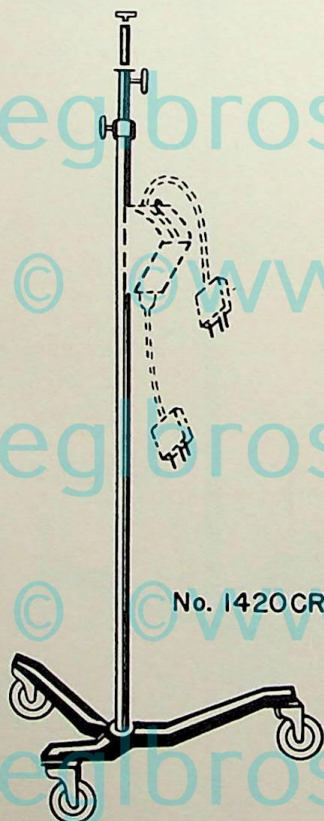

No. 1420CR

FLOODLIGHTS

New

18-INCH SCOOP



No. TV1155G

**The
Reliable
Workhorse
of the Studio**

This unit has a newly designed socket cap, with universally adjustable yoke and C clamp, permitting straight down as well as up lighting, Spring tension adjustment and perfect balance permit this unit to be angled from the floor. The scientifically designed aluminum reflector produces a smooth, even illumination of high intensity — extremely efficient. Used to augment base lights and to highlight areas. Its light weight also makes it ideal for field use. Takes a wide range of lamp wattages — can be dimmed.

Ideal for Field Use

No. TV1155G — Hood of 16-gauge matte Alzak-finished aluminum, cast aluminum socket cap, complete with swivel yoke (spring tension adjustment), malleable iron C clamp for 1½ to 2" pipe, grip handle, 3 feet #12 asbestos leads, and 3-pole (1 leg ground) #955G male connector. Takes 750, 1000, 1500, 2000, or 2500 watt #PS52 lamps.Price:

No. TV1155 — Same unit but with 2-pole male #955 connector (no ground leg).Price:

No. 1078 — Octagonal metal colorframes, with wire mesh guard — clips on.Price:

No. 1420CR — Roller caster stand, for scoops. 19-inch base. Height adjustable from 3 to 5 feet. Complete with yoke stud.Price:

No. 1421CR — Roller caster stand, as above, but 25 inch base.Price:

Rubber Cables

25-foot 3-conductor #12 rubber cable with #955G female connector and #955G male connector (includes ground leg).Price:

25-foot 3-conductor #12 rubber cable with #955G female connector and #315 plug (includes ground leg).Price:

25-foot 2-conductor #12 rubber cable with #955 female connector and #955 male connector (no ground leg).Price:

25-foot 2-conductor #12 rubber cable with #955 female connector and #301½ plug (no ground leg).Price:

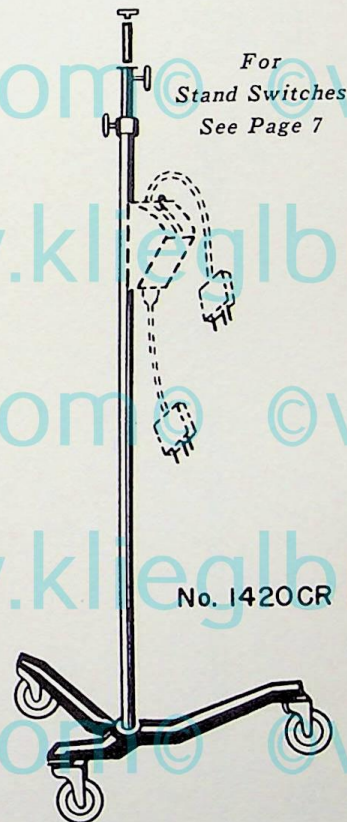

For
Stand Switches
See Page 7

No. 1420CR

For
Diffuser
See page 26

FLOODLIGHTS, *continued*

New 500-WATT
15-INCH SCOOP

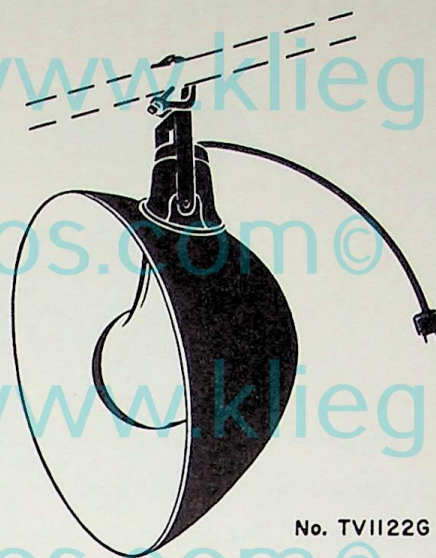

No. TV1122G

Newly designed and created to provide the lower intensities needed for the new orthicon tubes. Ideal for use from 10 to 12 feet ceiling. Produces a smooth even illumination of high intensity similar to the Reliable Work Horse Scoop described on opposite page. Equipped with a universally adjustable yoke and C clamp permitting straight down as well as up-lighting. This unit can be adjusted from the floor due to its perfect balance and spring tension adjustment.

Light in weight with an Alzak-finished reflecting surface, it is ideal for field use as well as studio use to augment the base light and to highlight areas. Takes either a 300 or 500 watt lamp — can be dimmed.

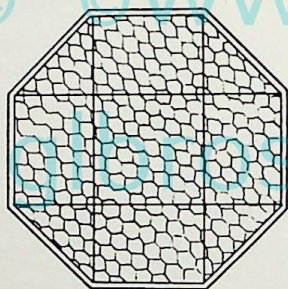

No. 1078C

No. TV1122G — Hood made of 16-gauge matte Alzak-finished aluminum, cast aluminum socket cap and complete with swivel yoke (spring tension adjustment), malleable iron C clamp for 1½ to 2" pipe, grip handle, 3 ft. #14 asbestos leads and 3-pole (1 leg ground), #955G male connector. Takes either a 300 watt #PS35 or the 500 watt #PS40 inside frosted lamp....Price:

No. TV1122 — Same unit with but 2-pole #955 male connector (no ground leg).Price:

No. 1078C — Octagonal metal colorframe with wire mesh guard, clips on. Price:

No. 1084 — Barn Door. Price:

No. 1420CR — Roller caster stand with 19 inch base, see opposite page. Height adjustable from 3 to 5 feet and complete with yoke stud.Price:

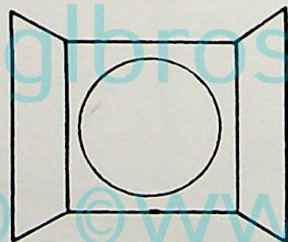

No. 1084

Rubber Cables

25 foot 3-conductor #14 rubber cable with #955G female connector and #955G male connector (includes ground leg).Price:

25 foot 3-conductor #14 rubber cable with #955G female connector and #315 plug, (includes ground leg).Price:

25 foot 2-conductor #14 rubber cable with #955 female connector and #955 male connector (no ground leg).Price:

25 foot 2-conductor #14 rubber cable with #955 female connector and #301½ plug (no ground leg).Price:

*For
Diffuser Mediums
See Page 26*

FLOODLIGHTS, *continued*

New

**LONG RANGE
SCOOP**



For the greater projection heights of 14 to 18 ft. this new "Punch" scoop produces the comparable light that the famous original scoops (see previous page) do at the lower 10 to 12 ft. ceiling heights. Consisting of a combination polished and matte Alzak aluminum reflector it produces with the frosted bulb, a smooth uniform efficient high intensity illumination. Its beam spread is adjustable, making it adaptable for a wide range of projection heights to augment the slimline base lighting and for high-lighting areas. Ideal for added smooth punch of light at the lower 12 ft. ceiling heights and for front lighting. Light in weight and equipped with the universally adjustable yoke and C clamp it can be readily adjusted from the floor to any desired vertical or horizontal direction.

No. TV1158G — Hood made of 16-gauge special Alzak aluminum with a combination polished and matte Alzak finish, aluminum socket cap and complete with swivel yoke (spring tension adjustment), malleable iron C clamp for 1½ to 2" pipe, grip handle, 3 ft. #12 asbestos leads (1 leg ground) and 3-pole #955G male connector. Takes frosted, 750-1000 watt, #T-24, base up burning, 1000 hour life lamps.Price:

No. TV1158 — Same unit with 2-pole #955 male connector (no ground leg). Price:

No. 1078B — Octagonal metal colorframe with wire mesh guard, clips on. Price:

No. 1420CR — Roller caster stand with 19 inch base. Height adjustable from 3 ft. to 5 ft. and complete with yoke stud.Price:

No. 1421CR — Roller caster stand with 25 inch base, as above. Price:

Rubber Cables

25-foot 3-conductor #14 rubber cable with #955G female and male connector (includes ground leg)Price:

25-foot 3-conductor #14 rubber cable with #955G female connector and #315 plug, (includes ground leg)Price:

25-foot 3-conductor #14 rubber cable with #955 female and male connector (no ground leg)Price:

25-foot 2-conductor #14 rubber cable with #955 female connector and #301½ plug, (no ground leg)Price:

*For
Stand Switch
See Page 7*

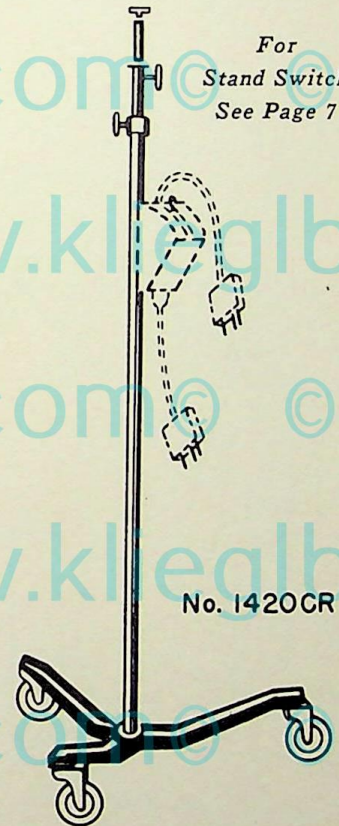

*For Diffuser Mediums
and Color Frames
See Page 26*

NEW 15-INCH KLIEGSUN

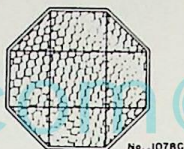

No. 1078C

For Diffuser Mediums, See Page 26

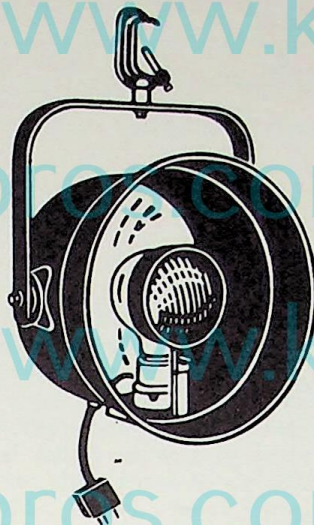

No. TV1143G

To meet studio requirements for a bright shaft of light, this newly designed "Kliegsun" offers the best combination of efficiency, size and weight. The one-piece 16-gauge aluminum housing and polished Alzak-finished "parabolic" aluminum reflector assures lightness in weight and efficient projection of the light. The front spherical shaped Alzak-finished aluminum reflector redirects the direct rays from the lamp bulb back into the parabolic reflector thereby greatly increasing the beam candlepower and at the same time eliminating all spill light. It has a rear operated spindle adjustment feed and is equipped with yoke and malleable iron C clamp for 1½ to 2" pipe, asbestos leads and male connector. It takes a wide range of lamp wattage and can be dimmed.

No. TV1143G — Hood of 16-gauge aluminum with a polished Alzak-finished parabolic aluminum reflector, front Alzak-finished spherical reflector, swivel yoke (spring tension adjustment), malleable iron C clamp, grip handle, 3 ft. of #12 asbestos leads and 3-pole (1 leg ground) #955G male connector. Takes 1000, 1500, 2000 watt G screw base lamps.
Price:

No. TV1143 — Same unit but with 2-pole #955 male connector (no ground). Price:

No. 1078C — Hexagonal metal colorframe, with wire mesh guard. Clips on. Price:

No. 1420CR — Roller caster stand with 19 inch base for above, height adjustable from 3 to 5 ft. and complete with yoke stud. Price:

No. 1421CR — Roller caster stand with 25 inch base, as above. Price:

Rubber Cables

25 foot 3-conductor #12 rubber cable with #955G female and male connectors (includes ground leg). Price:

25 foot 3-conductor #12 rubber cable with #955G female connector and #315 plug (includes ground leg). Price:

25 foot 2-conductor #12 rubber cable with #955 female and male connectors (no ground leg). Price:

25 foot 2-conductor #12 rubber cable with #955 female connector and #301½ plug (no ground leg). Price:

KLIEGL BROS. have over fifty years experience in the design and manufacture of lighting equipment and wiring devices for stage, movie, and TV productions.

We are staffed to furnish you expert engineering service to help you work out your studio lighting and wiring problems.

**PLAN
No. 1**

See Also Pages 16, 17

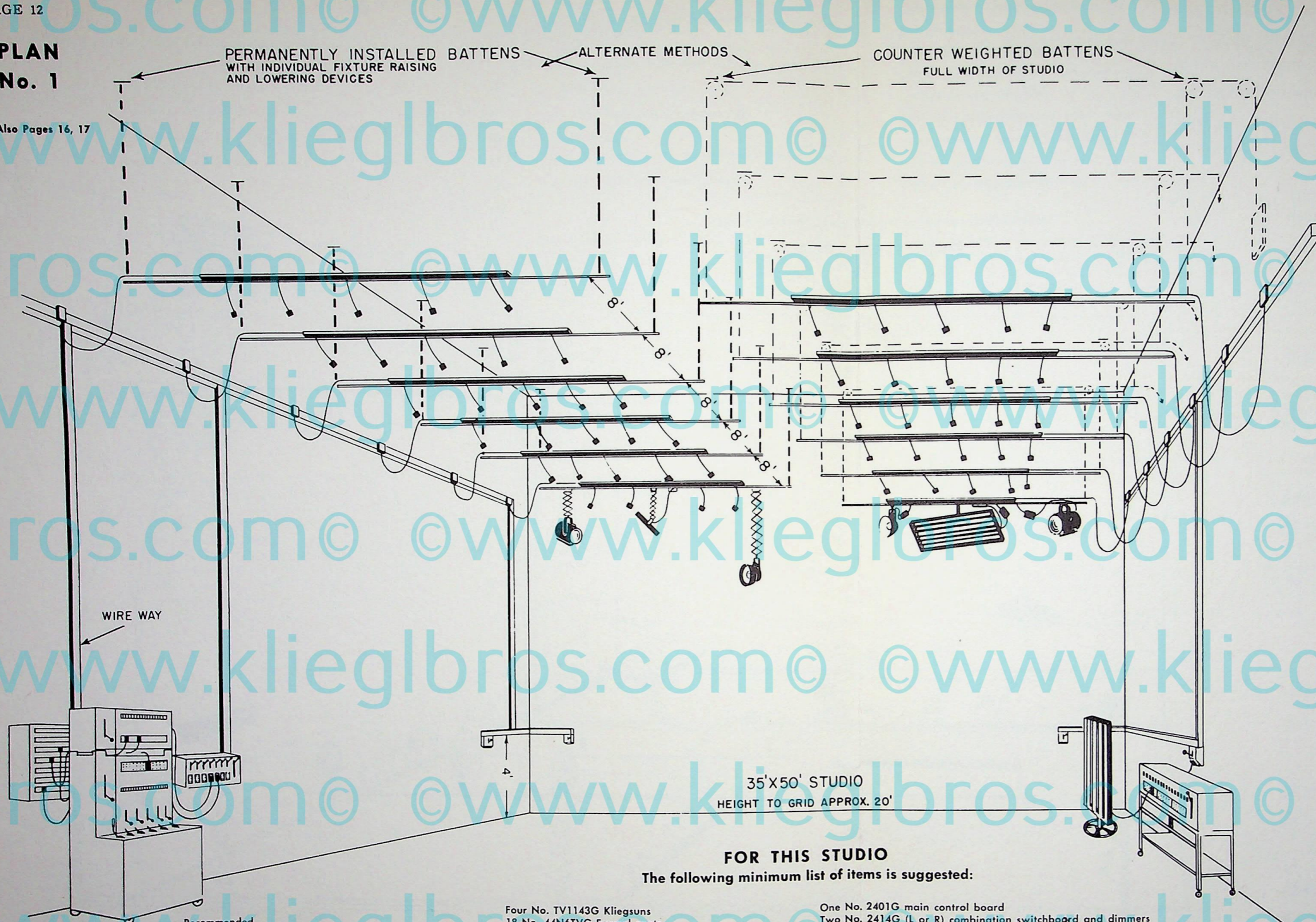

35'X50' STUDIO
HEIGHT TO GRID APPROX. 20'

FOR THIS STUDIO
The following minimum list of items is suggested:

Recommended ceiling outlets, 100
Minimum ceiling equipment, 80 units
Dimmer switchboard outlets, 30 each 15 amp. (10 dimmers)
Other switchboard outlets, 45 each 15 amp.
Main feed, 400 amp. 3φ 4-wire

Four No. TV1143G Kliegsuns
18 No. 44N6TVG Fresnel spots
18 No. 44N8TVG Fresnel spots
Four No. TV602G strip lights
Four No. TV464CRG portable floor floods
Two No. TV1178WG Dynabeams
Four No. TV1366EG Klieglights
Sundry hanging devices, cables, stands, etc.

One No. 2401G main control board
Two No. 2414G (L or R) combination switchboard and dimmers
Three No. 2409G (L or R) switchboards
One No. 2407G patchboard—100 circuits
Three No. 2405G wall outlets
18 No. 2432G connector strips with cables
12 No. TV664G (Or TV6WB64G3) slimline fixtures
12 No. TV1155G scoops
Eight No. TV1158G long range scoops

Months of study of TV studios under construction and in operation suggest a new method of wiring and installing lighting equipment. As a result, we have designed the

NEW KLIEGL PATCH-PLUG WIRING AND CONTROL SYSTEM

Plan No. 1 (on this page) is an example of this system in a

Permanent Installation

This new system speeds up studio production and effects big savings in installation and operational costs.

BIG SAVING No. 1

It provides sufficient fused outlets to enable a lamp unit to be moved anywhere in the studio without holding up production while a feed cable is brought over and laced into place. This results in immediate savings in operational cost.

BIG SAVING No. 2

It provides a switch control for each outlet, making possible another big cut in cost of operation.

BIG SAVING No. 3

It provides dimming control and a method of "patching in" any light or group of lights onto dimmers or non-dim circuits. This cuts down the usual large dimmer expense, and saves on cost of operation.

BIG SAVING No. 4

It provides the production department with facilities to put a picture on the air with all the desired niceties of lighting at a most reasonable initial cost and a minimum production cost.

BIG SAVING No. 5

It provides a sufficient number of outlets and lighting units so that two, three or four stages can be set up at a time. By simply "patching in" the circuits for each stage when used, complete lighting facilities are immediately available without having to move or redirect any lights. This arrangement practically permits a studio to be used continuously with an absolute minimum of costs.

For studios over 35x50, we recommend the permanent wiring system, although the portable wiring arrangement for smaller studios works equally well. The combination light and connector strip battens can be counterweighted, or permanently installed with the lights mounted on a Kliegl Hanging Device (see page 24). A sufficient number of light units should be installed to eliminate too frequent moving of them.

Our Engineering Department is at your service to assist in the layout and selection of equipment needed for your particular studio.

**PLAN
No. 2**

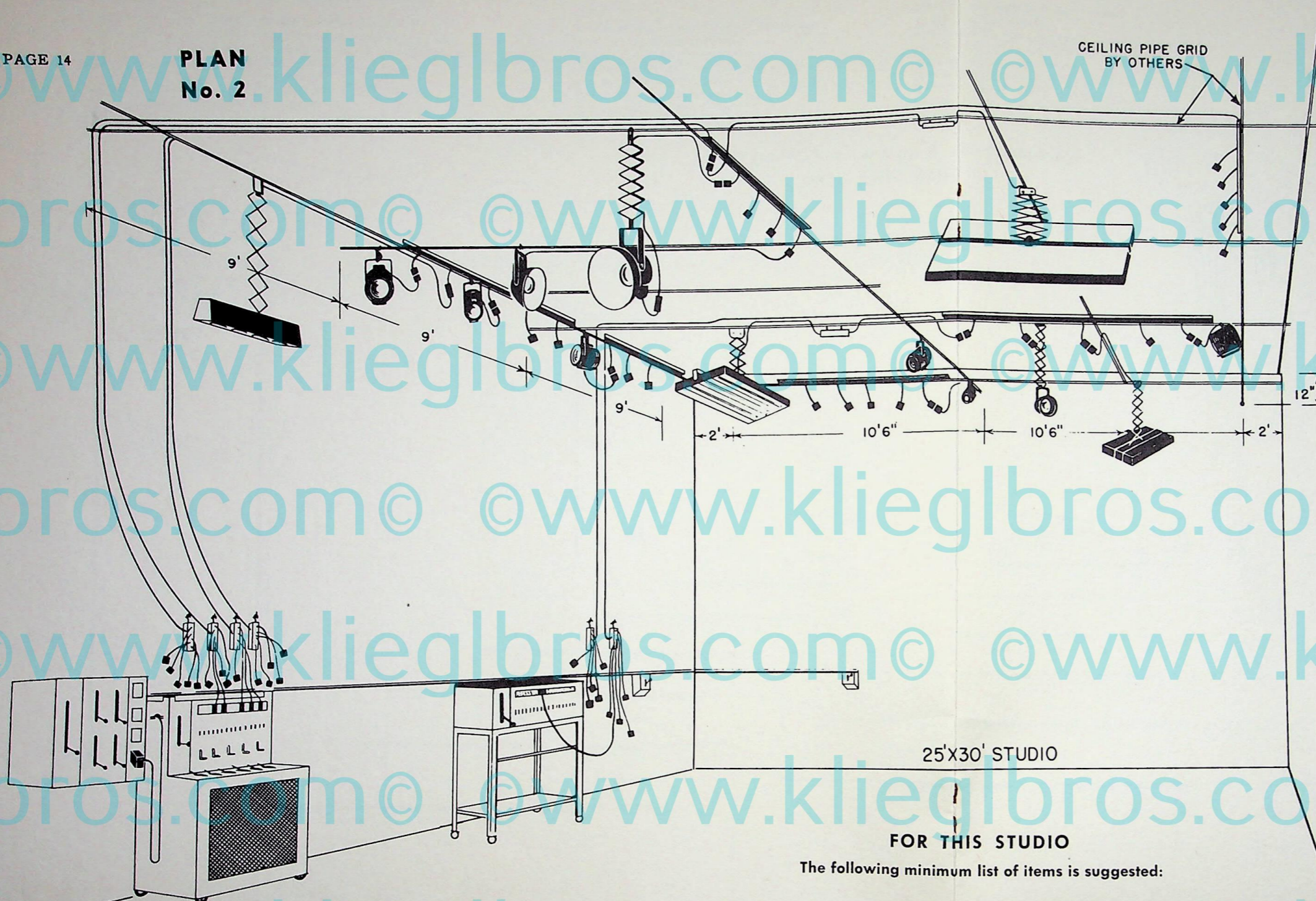

25'X30' STUDIO

FOR THIS STUDIO

The following minimum list of items is suggested:

Minimum ceiling outlets	40
Recommended ceiling outlets	60
Minimum ceiling equipment	40 units
Minimum dimmer switchboard outlets	15
Each 15 amp. (5 dimmers)	
Minimum non-dim switchboard outlets	30
Each 15 amp.	
Main feed	200 amperes 3 phase 4 wire

- One No. 2403G main control board
- One No. 2414G (L or R) combination switchboard and dimmer bank
- Two No. 2409G (L or R) switchboards
- Two No. 2405G wall outlets
- Eight No. 2440G patch plug sets with #2432G connector strips, cable and #2435G patch box.
- Eight No. TV464G slimline fixtures, with #TV464BG ballast boxes

- Eight No. TV1122G 500-watt scoops
- Three No. TV1155G 1000-watt scoops
- 16 No. 44N6TVG 500-watt Fresnel spots
- Three No. 44N8TVG 1000-watt Fresnel spots
- Two No. TV602G striplights
- Two No. TV464CRG portable floor floods
- One No. TV1174WG Dynabeam
- Two No. TV1365EG Klieglights
- Sundry hanging devices, cables, stands, etc.

Portable
**KLIEGL PATCH-PLUG
WIRING AND CONTROL SYSTEM**

The portable system enables the smaller studio to start with a modest investment, adding to its system from time to time as needs require.

The portable Kliegl Patch-Plug Wiring and Control System, shown here, is essentially the same as the Permanent system shown on pages 12 and 13. It provides:

- ... INDIVIDUAL FUSED SWITCH CONTROLLED OUTLETS
- ... ABILITY TO DIM AND PATCH CIRCUITS AS DESIRED
- ... FREEDOM TO SET UP TWO OR MORE STAGES FOR CONTINUOUS OPERATION

all tying together to produce better pictures at a minimum of initial and operational cost.

Study the two systems and note the cleancut appearance of the studios, the absence of floor cables and plugging boxes.

With each circuit fused 15 amperes, the most stringent code requirements are met.

The ground leg feature of this system completely protects your personnel and actors.

The flexible feed cables attached to the connector strips, permit moving and locating strips at the most convenient and economical position, as designated by current studio practice.

As your studio grows, additional connector strips can be added to augment the initial installation. The ends of the flexible cable terminate in a No. 2435G box which has "pigtailed" to plug in to the various switchboards in use. This feature allows main feeders to be smaller since current does not need to be provided for all ceiling outlets. Suggested feed is 200 amperes 3-phase 4 wire.

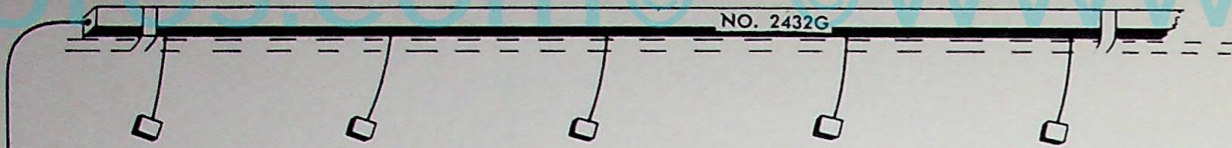

NO. 2440G
PORTABLE
PATCH PLUG SET

PLAN No. 2

No. TV2403G — Main distribution board, surface wall mounting. Main switch, 200 amp. 3 phase 4 wire, feeds 4 - 60 amp. 3 ϕ fused control switches each in turn feeding 1 - 60 amp. 4 wire (plus ground) female outlet. Patch cords are wired to location feeder boxes. Either switchboards or patch cords can be plugged into female outlets. Price: each

No. TV2405G — Location feeder box. Consists of a 60 amp. 3 pole switch and 60 amp. 4 pole plus ground #4957G female outlet (wired back to patch cord on main control panel). Portable switchboard can be energized here. Price: each

No. TV2409G (L or R) — Portable switchboard. Consists of 60 amp. 3 ϕ fused main switch, 15 - 15 amp. fused silent acting individual switches each wired to a #955G female grounded connector outlet. Furnished with 8 ft. #6 - 4g rubber cable and male #4957G connector which fits outlets on main distribution board and/or location feeder boxes. Non-grounded 2-pole male connectors, #955, can be fed from this board. Price: each

No. TV2418 — Roller Caster Stand for above portable control panels. Price: each

For dimmer switchboard see opposite page for description and prices.

No. TV2440G — Portable patch plug set. Consists of #2432G hanging connector strip, 7'-6" long, having five 4' No. 12 - 3 conductor (including ground) rubber cable pigtailed with #955G female connector attached and a #2435G patch box, 1 ft. long, having five 5-ft. No. 12 - 3 conductor (including ground) rubber pigtailed with #955G male connector attached, and with 25 feet No. 10G rubber cable wired between them.

Complete with mounting clamps and hanging hook on patch box. All wired. Price: each

No. TV2441 — Portable patch plug set, as above, except with six #955/20 amp. 2 pole (no ground) connectors on both the strip and patch box. Price: each

Extra multiple conductor cable for either of above, price per ft.

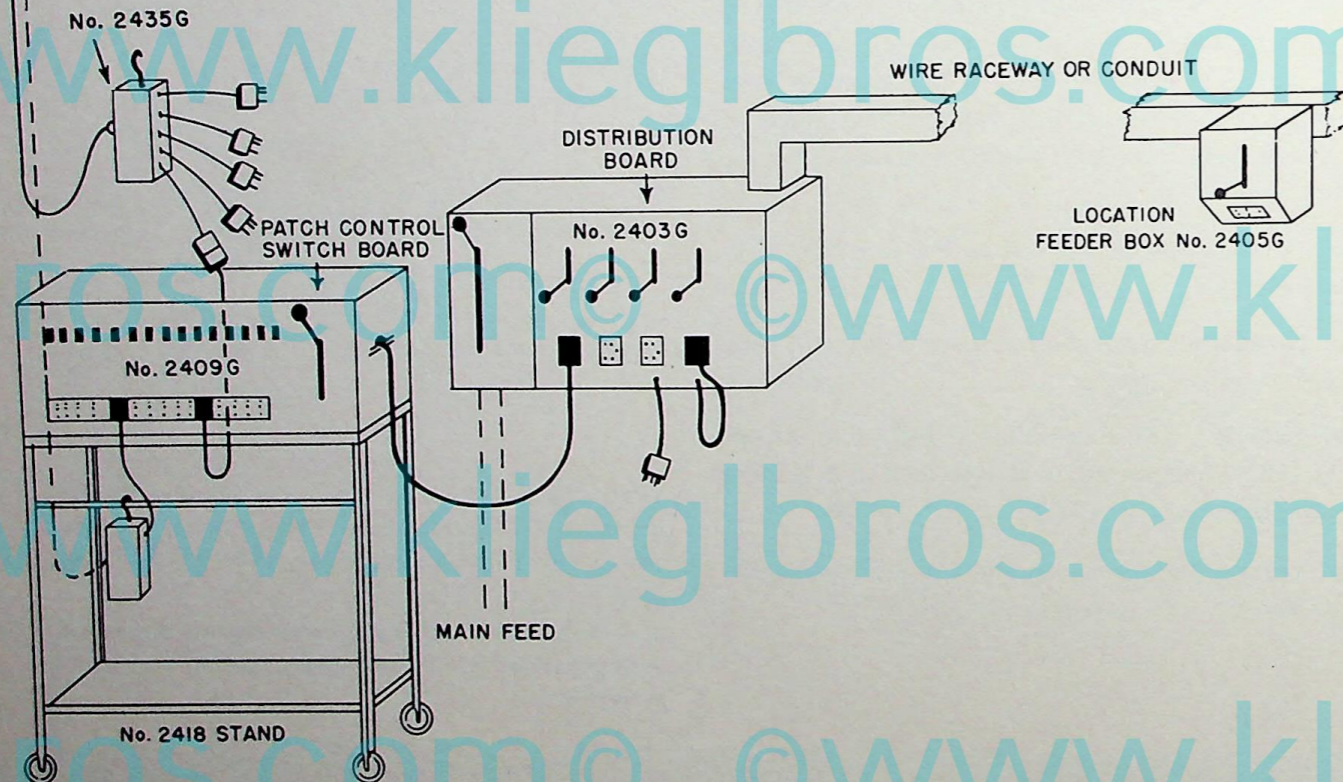

PLAN No. 1

No. TV2401G — Main Distribution Board—surface wall mounting. Consists of a 400 amp. 3 phase 4 wire fused main switch feeding 7 - 60 amp. 3 ϕ fused control switches, each of which feed an individual #4957G female 4 wire (plus ground) switchboard outlet. The 3 patch cords are wired to individual location feeder boxes. Price: each

No. TV2405G — Location Feeder Box (see opposite page for description and prices).

No. TV2407G — Patch Box—surface wall type in which all your ceiling circuits terminate in #955G male connectors. Contain 100 connectors. These circuits are energized by patch cords between them and the switchboards. Price: each

No. TV2407 — Patchboard as above, but with #955 male (no ground) connector. Price: each

No. TV2409G — Portable Switchboards (see opposite page for description and prices).

No. TV2414G — Dimmer Switchboard. Consists

essentially of portable switchboard combined with 5 autostat type dimmers each controlling 3 of the outgoing switches and outlets. In addition, each dimmer has its own individual fused silent acting switch. The dimmers have individual operating handles and the bank has one master dimmer handle. All metal construction, mounted on roller caster and complete with 8' 4G rubber feed cable and #4957G male connector which fits outlets on main distribution board and/or location feeder boxes. Non-grounded 2-pole male connectors, #955, can be fed from this board. Price: per ft.

No. TV2432G — 7'-6" long Connector Strips, wired for 5-4' (#12-3 cond. includes ground) rubber pigtailed with #955G female connectors, and with mounting clamps for 1½ pipe, terminal rack on feed end, and 25 ft. #12-10G rubber feed cable. Price: per ft.

No. TV2430 — As above, but with 6 - 2 pole (no ground) female connectors. Price: per ft.

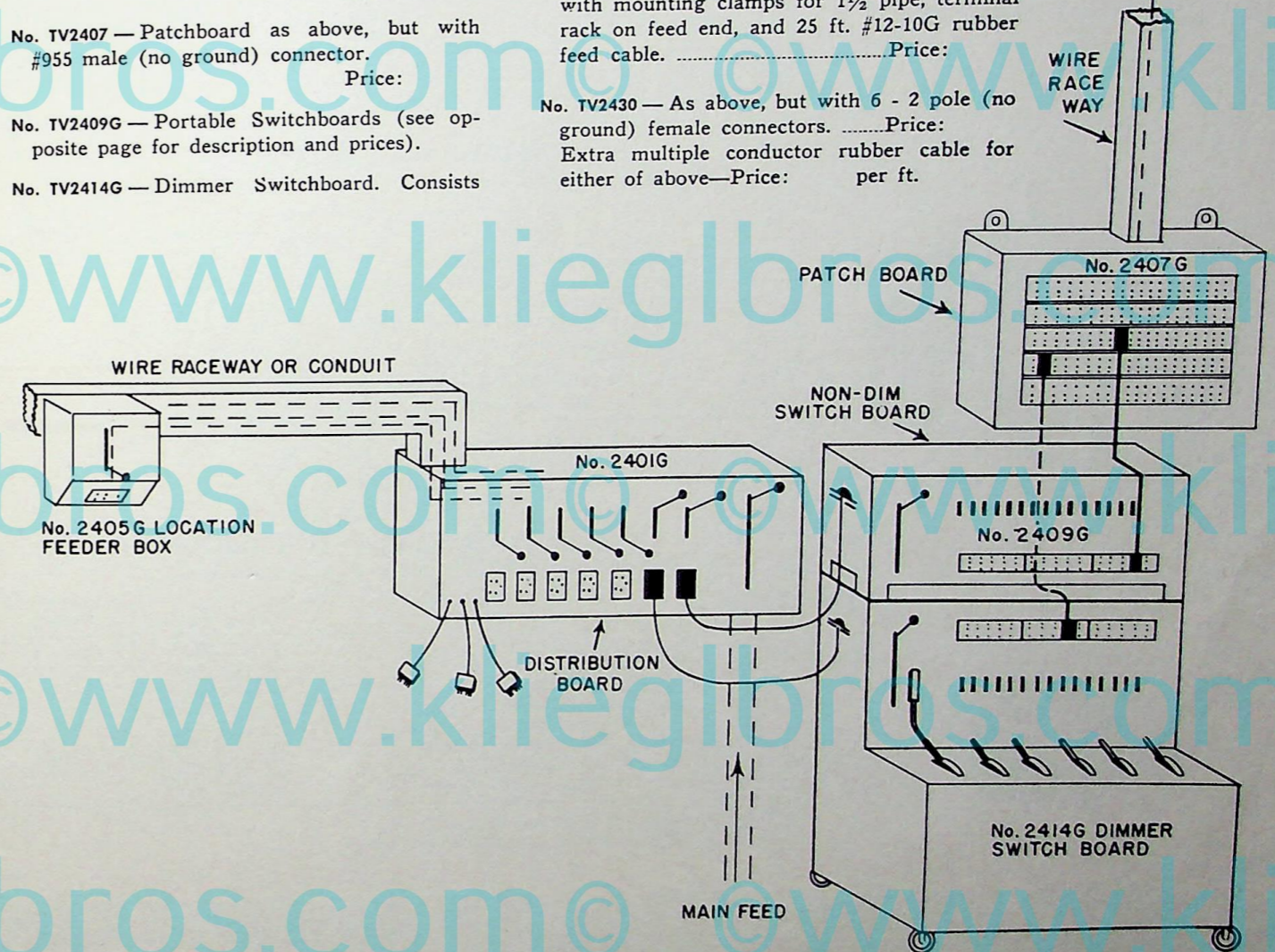

WIRING DEVICES, *continued*

FUSED PLUGGING BOXES GROUNDED SYSTEM



No. 476-3

All metal construction, Underwriters' approved, 2 wire 30 amp. porcelain with ground leg, made in any number of outlets, for any feed service.

2-wire feed — plus ground			3 wire feed — plus ground		
Cat. No.	Outlets	Price*	Cat. No.	Outlets	Price*
472	2		472-3	2	
474	4		474-3	4	
476	6		476-3	6	
478	8		478-3	8	

* Box prices do not include plugs
No. 315 — 2 pole plug with ground leg for above plugging boxes —

UNGROUNDED SYSTEM



No. 315



No. 301½



No. 301

Description	2-wire feed		3-wire feed	
	No.	Price*	No.	Price*
30-Amp Boxes (plugs extra)				
4 outlets	345-2		345-3	
6 outlets	346-2		346-3	
8 outlets	347-2		347-3	

No. 301½: 2-pole 30 amp plugs for above plugging boxes — each \$1.80

Description	2-wire feed		3-wire feed	
	No.	Price*	No.	Price*
50-Amp Boxes (plugs extra)				
4 outlets	404		405	
6 outlets	406		407	

No. 301: 2-pole 50 amp plugs for above plugging boxes —
* Box prices do not include plugs

UNFUSED WALL BOXES

FLUSH AND SURFACE WALL BOXES — FOR GROUND PLUG No. 315



No. 369

Cat. No.	Description	Type Box	Price*
361	Single Outlet; 2-wire plus ground	Flush Wall	
362	Two Outlets; each 2-wire plus ground	Flush Wall	
363	Three Outlets; each 2-wire plus ground	Flush Wall	
364	Four Outlets; each 2-wire plus ground	Flush Wall	
366	Single Outlet; 2-wire plus ground	Surface	
367	Two Outlets; each 2-wire plus ground	Surface	
368	Three Outlets; each 2-wire plus ground	Surface	
369	Four Outlets; each 2-wire plus ground	Surface	

* Box prices do not include plugs
No. 315 2-pole plug with ground leg for above boxes —
Combinations, other than those listed, available

UNFUSED WALL BOXES - NOT GROUNDED

FLUSH AND SURFACE TYPE FOR 301½ AND 301 PLUG



No. 311

Cat. No.	Description	Type Box	Price*
310	Single Outlet; 2-wire, 50 amp.	Flush Wall	
311	Two Outlet; 2-wire, 50 amp.	Flush Wall	
312	Three Outlet; 2-wire, 50 amp.	Flush Wall	
313	Four Outlet; 2-wire, 50 amp.	Flush Wall	
307	Single Outlet; 2-wire, 50 amp.	Surface Wall	
317	Two Outlet; 2-wire, 50 amp.	Surface Wall	
318	Three Outlet; 2-wire, 50 amp.	Surface Wall	
319	Four Outlet; 2-wire, 50 amp.	Surface Wall	

* Box prices do not include plugs
No. 301 — 50 amp. 2-pole plug for above boxes —

WIRING DEVICES

UNFUSED WALL FEEDER BOXES

All metal construction with separate ground terminal (can be used on undergrounded system).

WALL FEEDER BOXES — FOR REGULAR PLUGS

Rating Amp. Poles	Flush Types		Surface Types		Plugs	
	Cat. No.	Price*	Cat. No.	Price*	Cat. No.	Price
50 2	310G		307G		301	
100 2 Plus	1310G		1307G		1301	
50 3 Ground	2311G		2308G		2302	
100 3 Terminal	3310G		3307G		3301	

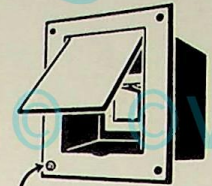

No. 1310G

GROUND TERMINAL

* Box prices do not include plugs

CONNECTORS

Cat. No.	Description	Price
955G	15/30 amp, 2 pole plus ground	
957G	60 amp, 2 pole plus ground	
4957G	60 amp, 4 pole plus ground	
3958G	100 amp, 3 pole plus ground	
955	15/30 amp, 2 pole	
956	30 amp, 2 pole	
957	60 amp, 2 pole	
958	100 amp, 2 pole	
3955	15 amp, 3 pole	
3956	30 amp, 3 pole	
3957	60 amp, 3 pole	
3958	100 amp, 3 pole	
4956	30 amp, 4 pole	
4957	60 amp, 4 pole	
4958	100 amp, 4 pole	

FLEXIBLE RUBBER CABLE

Cat. No.	Description	Price
14	2 conductor	per C
14	2G conductor	per C
12	2 conductor	per C
12	2G conductor	per C
10	2 conductor	per C
10	2G conductor	per C
6	2 conductor	per C
6	2G conductor	per C
6	4G conductor	per C
2	3 conductor	per C
2	3G conductor	per C

KLIEGL TV units assure complete electrical protection of studio personnel, actors and actresses.

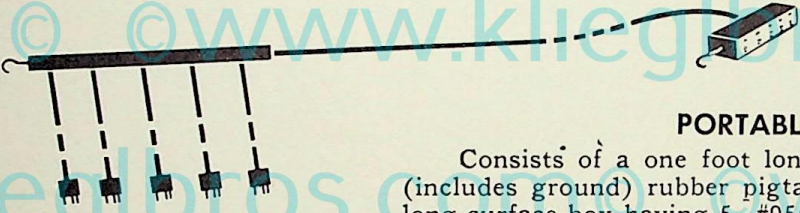

PORTABLE PATCH CORD SETS

Consists of a one foot long patch box having 5 - 3 ft. #12 3-conductor (includes ground) rubber pigtails with #955G male connector and a 9 inch long surface box having 5 - #955G female connectors flush mounted and with 25 ft. #12 — #10G rubber cable wired between them — for floor equipment outlets control by dim and non-dim boards. Price:

Alternate: Same arrangement but each end arranged for 6 - #955, 2-pole (no ground) 1/2 connectors. Price:

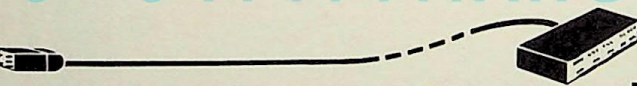

PORTABLE FUSED PATCH CORD SET

Consists of a fused plugging box on one end having 5 - #955G females each individually fused and a #4957G male plug on other end with 25 ft. #6 — #4G rubber cable wired between them — for floor equipment fed from a location feeder box. Price:

Alternate: Same arrangement but for 2 wire outlets (no ground) and 4-pole #4957 feeder (no ground). Price:

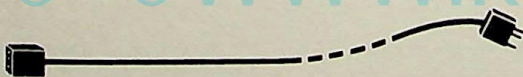

SWITCHBOARD PATCH CORD

Consists of 10 ft. #12 3-conductor (includes ground) rubber cable with #955G male one end and #955G female the other end. Price:

Alternate: Same arrangement but with #12 - 2 cable (no ground) and #955 male and female connectors. Price:

STRIP LIGHTS

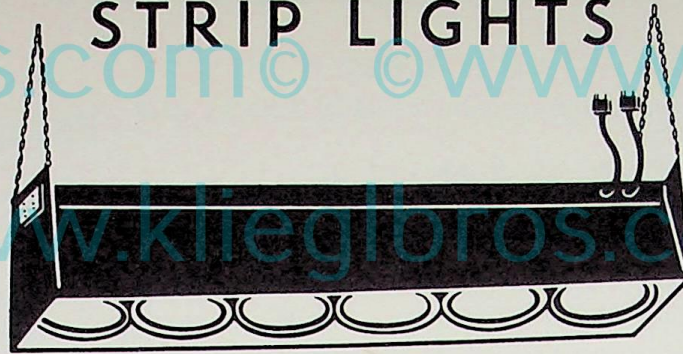

No. TV602G

STRIP WITH REFLECTORS

Ideal for background, ground row, footlight, behind doorways, etc. Equipped with alternately wired, polished and matte Alzak reflectors producing either narrow or medium beam shafts of light. End plate permits standing upright. Male pigtails allow plugging to adjacent strip. All aluminum construction — very light and very portable — equipped with chain hangers.

No. TV602G — Striplight 4 ft. long with 6 Alzak finished aluminum reflectors (3 polished—3 matte), wired on 2 alternate circuits. Complete with 2 - 2 ft. 3 conductor rubber pigtails with #955G male connector (1 leg ground) and 2 flush mounted #955G female connectors (1 leg ground). Equipped with chain hangers.
Price:

No. TV602 — Striplight as above but with 2 pole connectors (no ground leg)Price:

STRIPS FOR REFLECTOR LAMPS

No. TV600G — Striplight as above but without reflectors; comes equipped with chain hangers and 3 pole connectors (1 leg ground)Price:

No. TV600 — Striplight as above but with 2 pole connectors —no ground legPrice:

Reflector Lamp strips can be had wired for a single circuit with built-in switch controlling one-half the lamps, in place of the above, at no additional cost.

PORTABLE FLOOR FLOODS

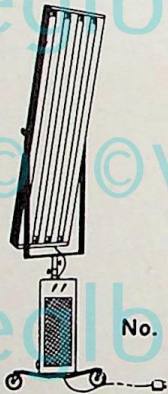

No. TV464CRG

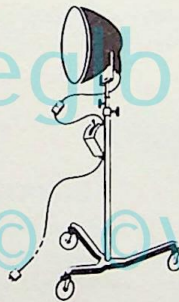

No. TV1157CRG



No. TV602CRG

No. TV464CRG — Portable 4 tube slimline on adjustable roller caster stand with individual Alzak finished reflectors and yoke, providing complete horizontal and vertical adjustment. Ballast box which is mounted on stand contains 2 switches for full on or 1/2 intensity—10 ft. cable between ballast box and fixture—furnished with 25' #14-3 conductor rubber (includes ground) feed cable and #955-G male connector.....Price:

No. TV1157CRG — Portable Work Horse Scoop on roller caster stand, height adjustment 4 to 6 ft. and complete

with 30 amp knife switch pigtail male and 4' pigtail female #955G connector, 25' #12-3 conductor rubber (includes ground) feed cable and #955G male connector.
Price:

No. TV602CRG — Portable TV602-3 Striplight on roller caster stand, height adjustment 4 to 6 ft. and complete with 30 amp knife switch, pigtail male and 4' pigtail female, #955G connector, 25' #12-3 conductor rubber (includes ground) feed cable and #955G male connector. Strip has inbuilt switch controlling 1/2 the lamps.

Price:

KLIEGLIGHTS

Klieglights are spot-flood lights which differ completely from conventional plano-convex lens and Fresnel lens units. Conceived by Kliegl engineers back in 1932 they have been perfected to the degree that they eliminate the necessity of using arc spotlights.

They produce a very brilliant, perfectly clear, uniform light which is easily controlled and molded into any desired pattern without any loss in the remaining area and without spill light. Perfect for highlighting areas and for front spotlighting. Ideal for use with projected scenery as their beam can be cut at any desired point.

Two models are available — the E type to hang from battens and the stand type for front lighting. Each model comes in two sizes providing sufficient light for either large or small studios.



No. 1366G E TYPE

No. 1365G — Junior Klieglight for 250, 500, 750 watt, T-14, medium bipost base up burning spot lamps — complete with Alzak-finished aluminum reflector, 4 independently adjustable square framing shutters, 6 inch stepped lens with ceramic black risers, asbestos leads and #955G male connector, yoke and C clamp.

Price:

No. 1366EG — Master Klieglight complete as above but for 1500-2000 watt, T base up burning, 200 hour life lamps.

Price:

Built-in adjustable iris shutter for above Klieglights can be furnished at additional cost of

No. 1174G — Super Klieglight for 2000 watt, T-30 — 200 hour life, base up burning lamp complete with roller caster stand, switch, 25 ft. (3- conductor includes ground) cable, #955G male connector, rear operated curtain and iris shutter, 12 inch diameter lens — produces 450 foot candles average in a maximum 4 ft. spot at 25 feet.Price:

No. 1174WG — As above but with 8 inch diameter lens, producing 200 ft. candles average in a maximum 7 ft. spot at 25 feet.

Price:

No. 1178G — Dyna-beam Klieglight similar in design to the super model but uses a 3000 watt, T-32 — 200 hour life, base up burning lamp. It has an added feature of a built-in rear operated horizontal spread lens which doubles the width of the projected spot when desired. It produces 1000 foot candles average in a maximum 4 ft. spot at 25 feet.Price:

No. 1178WG — As above Dyna-beam but with an 8 inch lens producing 500 foot candles in a maximum 7 ft. spread at 25 feet.

Price:



No. 1178G STAND TYPE

BOOM STAND

A quick mobile unit to produce back lighting in those hard-to-get-to locations. Easily clears a 10 ft. scenic flat. Horizontal and vertical adjustments are made from the floor. Perfectly balanced.

No. 2121G — Boom stand with all aluminum constructed 8 inch Fresnel spotlight complete with spindle feed, Alzak-finished aluminum reflector, 25 ft. #12-3-conductor (includes ground) rubber cable and #955G male connector.Price:

No. 2121 — Boom stand with all aluminum constructed 8 inch Fresnel spotlight complete with spindle feed, Alzak-finished aluminum reflector, 25 ft. #12-3-conductor (includes ground) with 2 wire rubber cable and #955G male connector.

Price:



No. 2121-3

Conversion of Theaters to Television Studios

Experience gained in converting numerous theatres to television studios suggests that it be best to treat each theatre as an individual problem. The structural design of the theatre, stage, balcony, etc., determines to a great extent the type and location of the equipment. The patch-plug wiring system has already been standardized by several of the studios, incorporated with a patch board and new switchboard, although it may be possible to re-convert the existing switchboard to use with the system. Such instances exist already.

Generally, you will require a battery of long-range scoops coupled with 8 inch Fresnels and 2000 watt Klieglights on the balcony rail. From the balcony you will also need two super or Dyna-beam Klieglights as follow and highlighting front spots. If conditions are favorable a set of long range scoops should be installed in the two side areas between the balcony front and proscenium arch. A few scoops mounted on the proscenium arch would take care of audience participation lighting.

For the stage, you will require hanging overhead — slimlines — scoops — 6- and 8-inch Fresnel, and 500 watt Klieglights. Battens should be not more than 7 ft. apart. Side towers and/or ladders supporting Klieglights, scoops and 6- or 8-inch Fresnels are needed in each entrance.

Strips are used for cyclorama lighting and the scenic projector for projected scenery and effects.

We will gladly make a complete layout for you and suggest you forward a plan of your theatre which will enable our engineers to assist you in making recommendations. There is no charge for this service.

KLIEGL BROS. have over fifty years experience in the design and manufacture of lighting equipment and wiring devices for stage, movie, and TV productions.

Our standard equipment can be modified to meet your special requirements, and we can design and manufacture special units to your specifications.

BACKGROUND PROJECTOR

No. 1674G — Scenic slide and effect projector for 2100 watt 60 volt lamp, complete with roller caster stand, transformer, switch and 25 ft. #12 - 3-conductor (includes ground) rubber cable and #955G male connector, exhaust blower, heat absorbing glass with blower, heat absorbing glass with blower, slide carrier for 3 3/4 x 4 slides and full size 8 inch objective lens. No lamp. (Can be arranged for pipe mounting at no additional cost.)

Price:

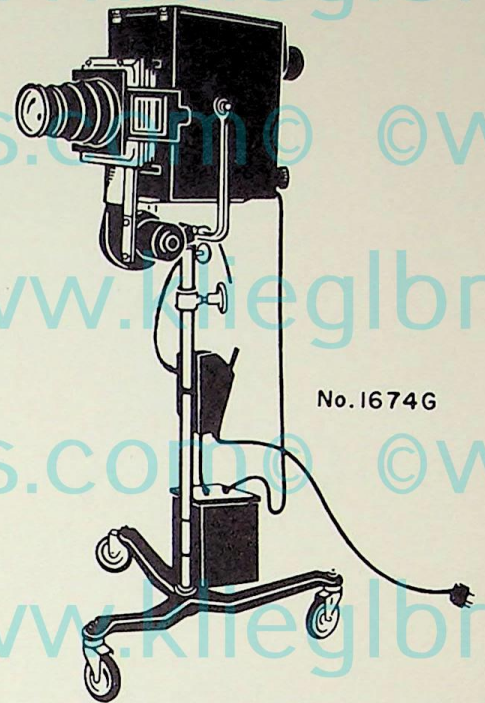

No. 1674G

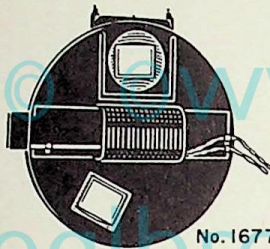

No. 1677

No. 1677 — SLIDE CHANGER.

For 7 slides. Motor operated, with remote control. 18 inch diameter.

Price:

SCENIC EFFECTS

Hand-painted moving effects are particularly adapted for TV projection, using the AC motor driven projector pictured at the right. The following effects are always useful:

- No. 135 — Moving fleecy clouds, black background.
- No. 138 — Moving storm clouds.
- No. 129 — Moonlight water ripple.
- No. 132 — Moving clouds with rising or setting moon.
- No. 164 — Rising fire and smoke (double disc).
- No. 98 — Falling leaves.
- No. 151 — Ocean wave.

A wide assortment of other scenic effects is also carried in stock. Special effects and slides painted to order.

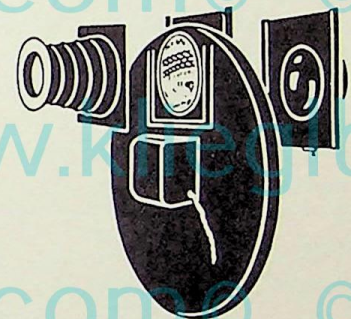

EFFECTS WITH CASING
AC MOTOR DRIVEN

ELECTRO-MECHANICAL EFFECTS

Artificial fire logs in all sizes (with or without moving flames):

- | | |
|-----------------------------|----------------------|
| Automatic lightning striker | Shoe plates |
| Chemical smoke | Hand sets |
| Flash boxes | Crystal showers |
| Noise of wind | Radium paint |
| Noise of thunder | Ultra-violet filters |
| Mephisto spark mate | |

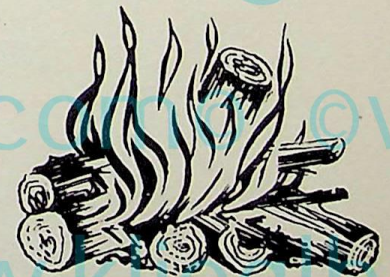

These and a host of other electro-mechanical effects are available generally from stock. Prices on application. Special effects made to order.

HANGING DEVICES



No. TV111

No. TV111 — Kliegl single-spring counter-balance raising and lowering device for use with Scoop, Long Range Scoop, Kliegsun, #44N6 Fresnel Spot, or 500-watt Scoop. Permits 360° horizontal rotation. Yoke on units provides vertical tilt. This device eliminates costly counter-balanced battens, yet provides means of positioning the light where needed. Price:

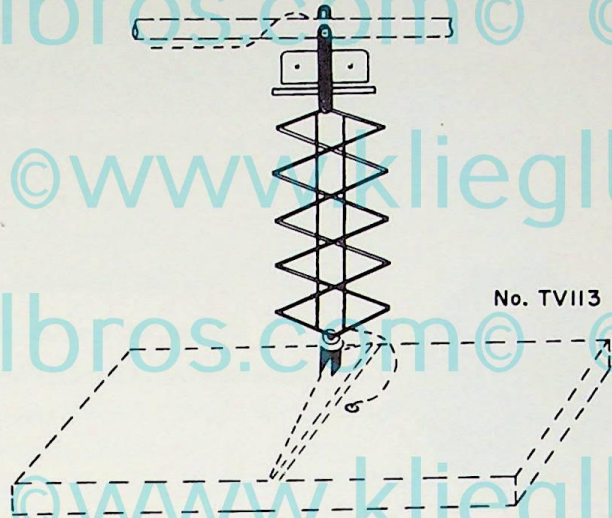

No. TV113

No. TV112 — Same as TV111, but designed to accommodate #44N8 unit. Price:

No. TV113 — Kliegl double spring counter-balanced device, as shown above, for use with #44N12 Fresnel spots or with slimline (with ballasts separate). Price:

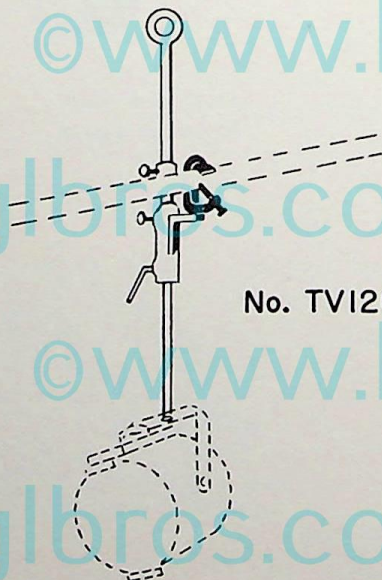

No. TV120

No. TV120 — Kliegl raising and lowering device for all TV lighting units — clamps to batten. Provided with set screws, safety collar, and hanging hook for pulley system. Provides 360° horizontal rotation — yoke on units provides vertical tilt. Standard length of adjustment, 6 feet — other lengths available. Price:

HANGING DEVICES, *continued*



No. TV119 — Double C clamp for supporting secondary grids. Also provides a quick means of supporting additional light and scenery battens. Easily adjusted. Takes 1½ to 2" pipe. Price: each

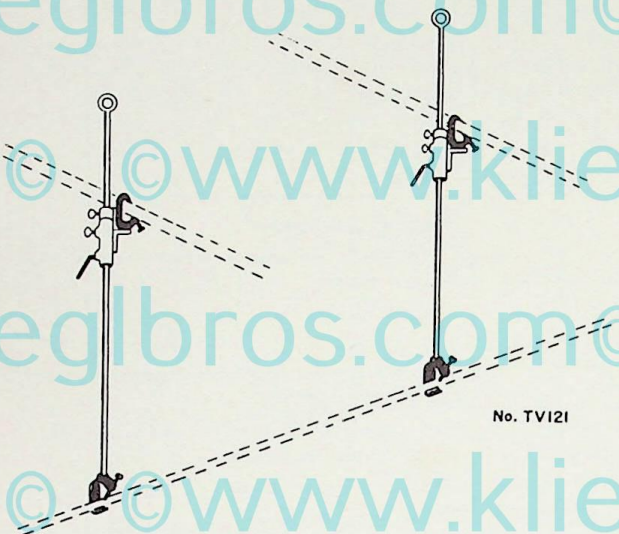

No. TV121 — Raising and lowering device to support a light batten at a variable height below the permanent grid. Easy to move. Standard height adjustment, 6 feet. Other adjustment lengths available. Price: per Pair

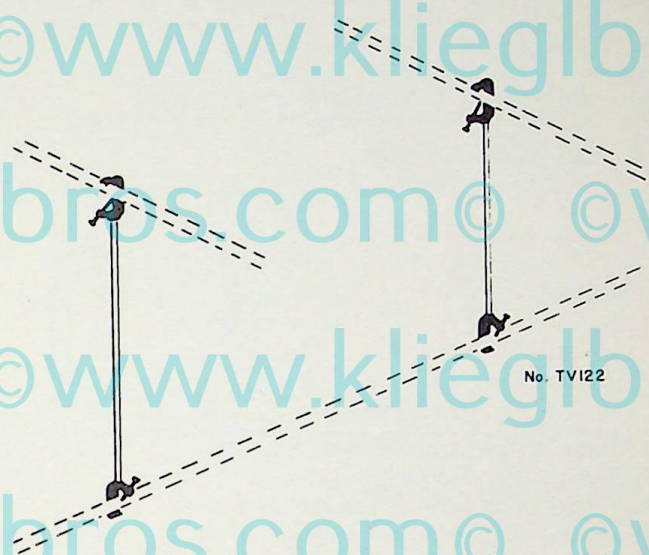

No. TV122 — Non-adjustable device for quickly supporting a light or scenery batten below the permanent grid. Easy to move. Standard length, 4 feet. Other lengths available. Price: per Pair

PORTABLE SCENERY SUPPORT

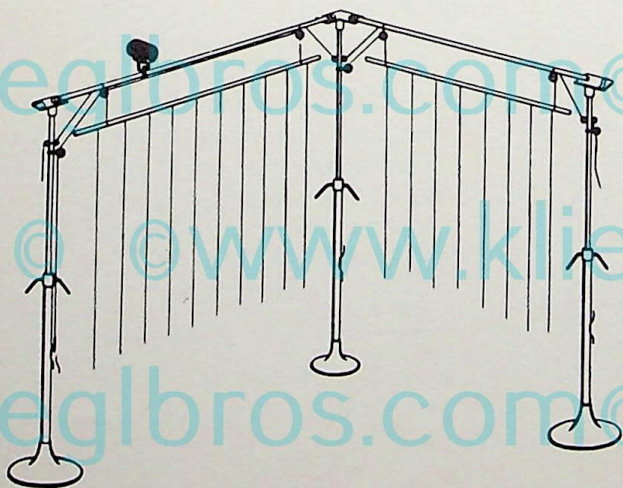

Provides a quick and economical means of supporting lights and scenery. Assembled quickly into practically any shape — square, oblong, single corners, etc. Provided with pulleys for raising and lowering battens or scenery. Standard height is adjustable from 8 to 10 feet. Furnished complete with tie-off cleats, 3-gang pulley blocks, top Double-C swivel pipe clamps and braces. No pipe battens. Price: per Stand

ACCESSORIES and LAMPS

2 - WAY BARN DOORS

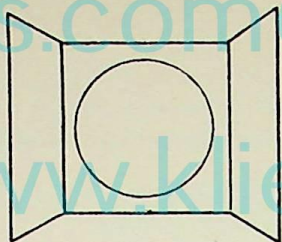

No. 1080

- No. 1080 — For #43N6 Fresnel spot
- No. 1081 — For #43N8 Fresnel spot
- No. 1082 — For #43N12 Fresnel spot
- No. 1083 — For #43N16 Fresnel spot
- No. 1084 — For #1122 scoop and 1143 Kliegsun ..

4 - WAY BARN DOORS

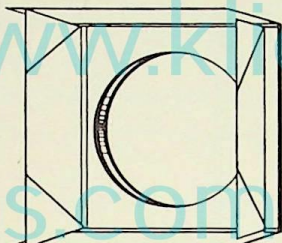

No. 1080A

- No. 1080A — For #43N6 Fresnel spot
- No. 1081A — For #43N8 Fresnel spot
- No. 1082A — For #43N12 Fresnel spot
- No. 1083A — For #43N16 Fresnel spot
- No. 1084A — For 1122 scoop and 1143 Kliegsun ..

DIFFUSER MEDIUMS

- 20 x 24" frosted gelatineper sheet,
- Spun glass diffuser, 12' roll, 36" wide x .015 thicknessper roll,
- Fibreglass diffuser, 26" wide up to 45 yds. in lengthper yard,

COLORFRAMES:

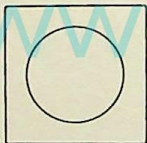

No. 1036

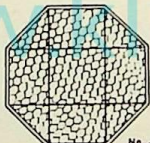

No. 1078C

All colorframes are sturdily designed to take either gelatine, spun glass or fibreglass diffusers. Larger sizes have wire reinforcements.

- No. 1032 — For #43N3 Fresnel spot
- No. 1036 — For #43N6 Fresnel spot
- No. 570F — For #43N8 Fresnel spot
- No. 578 — For #43N12 Fresnel spot
- No. 585 — For #43N16 Fresnel spot
- No. 1078C — For #1122 scoop and for 1143 Kliegsun
- No. 1078 — For #1155 scoop
- No. 1078B — For #1158 scoop

Recommended LAMPS

FOR FRESNEL SPOTS

Unit No.	Watt	Bulb	Base	Life Hrs.	Price
43N3	100	G-16½	Double contact bayonet	200	
43N3	150	G-16½	Double contact bayonet	200	
43N6	250	G-30	Medium prefocus	200	
43N6	400	G-30	Medium prefocus	200	
43N6	500	G-30	Medium prefocus	500	
43N6	750	T-20	Medium prefocus	25	
43N8	1000	G-40	Mogul prefocus	200	
43N8	1500	G-40	Mogul prefocus	200	
43N8	2000	G-48	Mogul prefocus	200	
43N12	1000	G-48	Mogul bipost	100	
43N12	2000	G-48	Mogul bipost	200	
43N16	5000	T-64	Mogul bipost	75	

FOR KIEGSUN

1143	1000	G-40	Mogul screw	200
1143	1500	G-40	Mogul screw	200
1143	2000	G-48	Mogul screw	200

FOR BABY SCOOP

1122	300	PS35	Clear medium screw	1000
1122	500	PS40	Clear medium screw	1000
1155	750	PS52	Clear mogul screw	1000

FOR WORK HORSE SCOOP

1155	1000	PS52	Clear mogul screw	1000
1155	1500	PS52	Clear mogul screw	1000
1155	2000	PS52	Clear mogul screw	1000
1155	2500	PS52	Clear mogul screw	1000

FOR LONG RANGE SCOOP

1158	750	T-24	Medium bipost base up	1000
1158	1000	T-24	Medium bipost base up	1000

FOR KIEGLIGHTS

1365	250	T-14	Medium bipost base up	800
1365	500	T-14	Medium bipost base up	200
1174	1500	T-24	Mogul bipost base up	200
1174	2000	T-30	Mogul bipost base up	200
1178	3000	T-32	Mogul bipost base up	200

FOR EFFECT PROJECTOR

1674	2100	T-20	Mogul bipost	75
------	------	------	--------------	----

A host of other lamps are available for use in Kliegl equipment, including all short life photo bulbs. We will gladly send the complete list on inquiry.

GENERAL LIGHTING

Besides our regular television and theater lighting equipment, we offer a complete line of general lighting units, such as . . .

- Downlights
- Pinhole Lights
- Flush Recessed Lens Lights
- Slimline Fixtures
- Fluorescent Fixtures

- Wall Lighting Units
- Wall Lighting Strips
- Picture Projectors
- Outdoor Floodlights
- And numerous other items.

The complete line is listed in our Architectural Catalog. The following items, selected from this large catalog, will be found useful in meeting your non-studio lighting problems.

NOTE:— Complete Architectural Catalog free on request. If you require non-studio lighting units, other than listed here, be sure to send for our Architectural Catalog, describing and illustrating the complete KLIEGL line of general lighting equipment. Address: KLIEGL BROS., 321 West 50th Street, New York 19, N. Y.

No. 276



Surface or flush types with adjustable beam control, confining the light to the areas required without any spill light.

SCRIPT LIGHTS

No. 276 — 100 watt surface mounting type with adjustable square framing shutters—covers a maximum area of 1/2' for each foot of throw. Price:



No. 2145

No. 2145 — As above, but for flush ceiling mounting. Price:

No. 2146 — Same as #2145 but for angular projection up to 45°. Price:

No. 6946



No. 6945 — Flush wall EXIT—5" letter. Price:

EXIT SIGNS

No. 6946 — Flush wall EXIT—6" letter. Price:

No. 6948 — Flush wall EXIT—8" letter. Price:

No. 685 — Surface wall EXIT—5" letter. Price:

No. 686 — Surface wall EXIT—6" letter. Price:

No. 687 — Surface wall EXIT—8" letter. Price:



No. 685

Come in 2 standard models—flush and surface type, with 5 different glasses reading—"On Air", "Rehearsal"—"Audition"—"Standby"—"Silence".

WARNING LIGHTS



Flush type—2" letter, Catalog #TV6940. Price:

Surface type—2" letter, Catalog #TV680. Price:

FLUSH LENS-LIGHTS

General Lighting

No.	Lens		Lamp Watts	Price
	Shape	Size		
22F06	Circular	6"	100	
22F08	Circular	8"	150	
22F12	Circular	12"	200/300	
22F14	Circular	14"	300/500	
22F16	Circular	16"	500/750	
24F06	Square	6"	100	
24F08	Square	8"	150	
24F12	Square	12"	200/300	

No. 23F12





**ORIGINATORS
AND
MANUFACTURERS
OF
THE FAMOUS**

***Kliegl**light*

KLIEGL BROS

UNIVERSAL ELECTRIC STAGE LIGHTING CO., INC.

321 WEST 50th STREET

NEW YORK 19, N. Y.

CATALOG TV-5